

MODELS: XTRM-1 (1.5" opening) XTRM-2, 2M* (1.5" opening)
 XTRM-2H, 2HM* (3" opening) XTRM-3, 3M* (1.5" opening)
 XTRM-3H,3HM* (3" opening)

*M denotes Marine option

X*TRM-1



X*TRM-2



X*TRM-3



OPTIONS & ACCESSORIES

- Stacking Kit (XTRM-2 & XTRM-3)
- Gluten Free Top Label-Purple, Covers top, front, rear, and partial areas of the sides.
- Marine Package USPH Compliant:
 - ◊ All External and Food Zone Fasteners are hex head (No Flat or Phillips)
 - ◊ 4" flanged feet for mounting
 - ◊ Available on the 2, 2H, 3, & 3H models

FEATURES AT A GLANCE

- Small counter space footprint
- "Cool Touch" exteriors prevent injuries
- Power saver switch reduces energy consumption by 50%.
- Removable side panel for service
- High temperature bearings never require lubrication
- Stainless steel housing with powder-coated aluminum front corners
- Metal sheathed heating elements out-perform competitive quartz tube heating
- XTRM-2 and XTRM-3 feature stainless steel conveyor belt
- One inch adjustable legs.

WARRANTY

These units come with a one [1] year warranty for parts and labor. International or marine package toaster warranty is one [1] year parts only.

TOASTING CAPACITY*

XTRM-1: 350 slices per hour
 XTRM-2,2M: 800 slices per hour
 XTRM-2H,2HM: 600 slices per hour
 XTRM-3,3M: 1050 slices per hour
 XTRM-3H,3HM:800 slices per hour

CONSTRUCTION

- Stainless steel top skirt, grease trough, grease collector drawer, and front panel. Stainless steel radiant. Aluminized steel sides and back panel. 1" minimum standard leg height, 4" adjustable legs optional. Welded construction.

ELECTRICAL SPECIFICATIONS

- Equipped with a 39" three wire grounded power cord and standard three pronged male plug. U.S. 120V units use a NEMA 5-15P plug. Canadian 120V units use a 5-20P plug, 208V, 240V, and 230V use a NEMA 6-20P plug. CE 230V/50Hz unit uses a European Type "D" plug

CERTIFICATIONS

Certified by the following agencies:



RADIANT CONVEYOR TOASTER

MODELS: XTRM-1 (1.5" opening) XTRM-2, 2M* (1.5" opening)
 XTRM-2H, 2HM* (3" opening) XTRM-3, 3M* (1.5" opening)
 XTRM-3H, 3HM* (3" opening)

EQUIPMENT DIMENSIONS

Model	A (Width)	B (Depth)	C (Height)	D (Opening)
XTRM-1	15.19"	16.75"	12.22"	10.5"
XTRM-2	15.69"	16.75"	15.0"	10.5"
XTRM-2H	15.69"	16.75"	16.5"	10.5"
XTRM-3	18.69"	17.03"	15.0"	13.5"
XTRM-3H	18.69"	17.03"	16.5"	13.5"

Product opening height is 1 1/2" on the XTRM-2 and XTRM-3
 Product opening height is 3" on the XTRM-2H and XTRM-3H

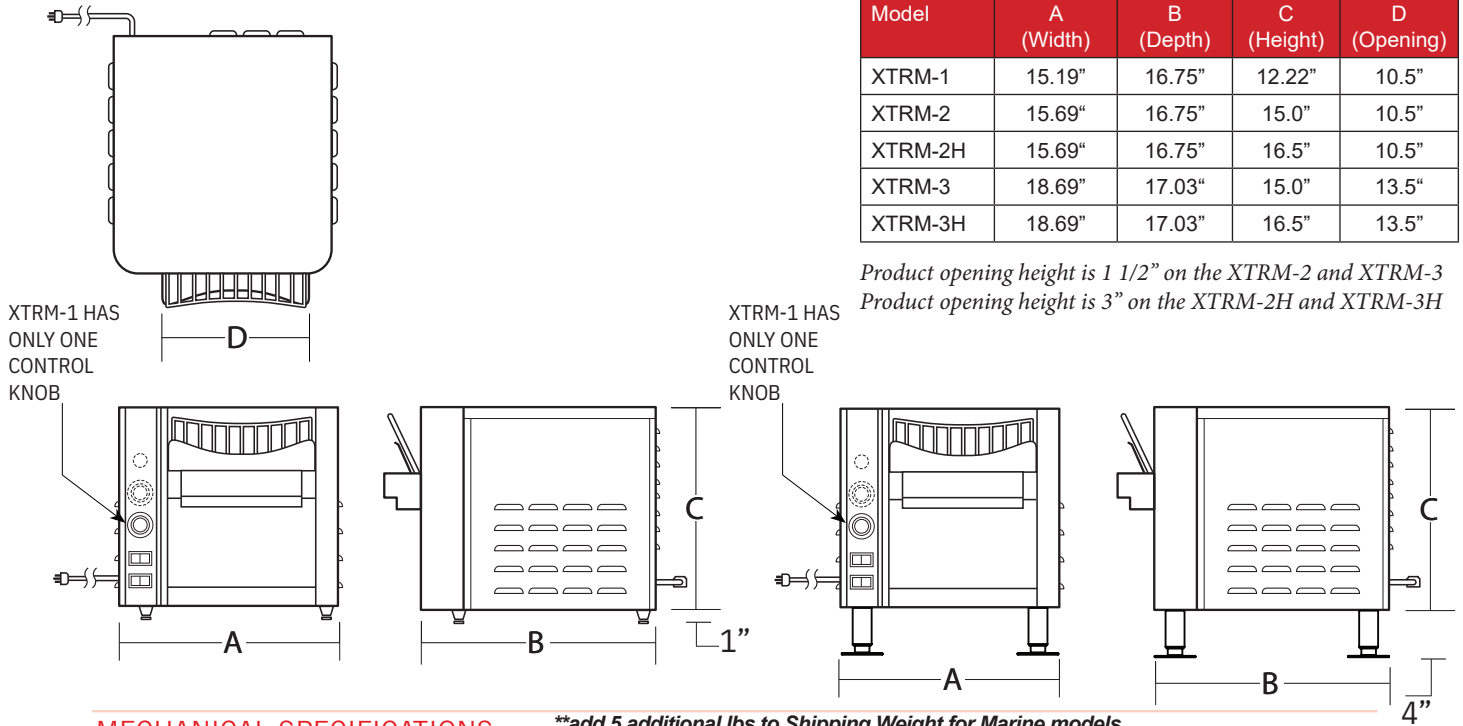

MECHANICAL SPECIFICATIONS

**add 5 additional lbs to Shipping Weight for Marine models

Model #	Watts	Voltage	Phase	Amps	Overall Dimensions		Ship Weight**
					Width (A) x Depth (B) x Height (C) (inches)	Opening Height (D)	
XTRM-1	1725	120	1	14.4	15.19" x 16.75" x 12.22"	10.5"	45 (15.8)
XTRM-1	1725	208	1	8.2	15.19" x 16.75" x 12.22"	10.5"	45 (15.8)
XTRM-1	1725	240	1	7.2	15.19" x 16.75" x 12.22"	10.5"	45 (15.8)
XTRM-1	1725	230	1	7.5	15.19" x 16.75" x 12.22"	10.5"	45 (15.8)
XTRM-2, 2M	2840	208	1	13.6	15.69" x 16.75" x 15.0"	10.5"	50 (22.7)
XTRM-2H, 2HM	2840	208	1	13.6	15.69" x 16.75" x 16.5"	10.5"	54 (24.5)
XTRM-2, 2M	2840	240	1	11.8	15.69" x 16.75" x 15.0"	10.5"	50 (22.7)
XTRM-2H, 2HM	2840	240	1	11.8	15.69" x 16.75" x 16.5"	10.5"	54 (24.5)
XTRM-2, 2M	2840	230	1	12.3	15.69" x 16.75" x 15.0"	10.5"	50 (22.7)
XTRM-2H, 2HM	2840	230	1	12.3	15.69" x 16.75" x 16.5"	10.5"	54 (24.5)
XTRM-3, 3M	3340	208	1	16.0	18.69" x 17.03" x 15.0"	13.5"	56 (25.4)
XTRM-3H, 3HM	3340	208	1	16.0	18.69" x 17.03" x 16.5"	13.5"	61 (27.7)
XTRM-3, 3M	3340	240	1	14.0	18.69" x 17.03" x 15.0"	13.5"	56 (25.4)
XTRM-3H, 3HM	3340	240	1	14.0	18.69" x 17.03" x 16.5"	13.5"	61 (27.7)
XTRM-3, 3M	3340	230	1	14.0	18.69" x 17.03" x 15.0"	13.5"	56 (25.4)
XTRM-3H, 3HM	3340	230	1	14.0	18.69" x 17.03" x 16.5"	13.5"	61 (27.7)

Freight Class: 100

FOB: Smithville, 37166

APW Wyott reserves the right to modify specifications or discontinue models without incurring obligation. Dimensions nominal.