



# CTF-T

## Countertop Freezer & Ice Cream Freezer

# KEY ASPECTS

## SPECIAL FEATURES:

- 3 adjustable shelves (CTF-2T)
- 2 adjustable shelves (CTF-1T)
- Right hinge self closing door
- Environmentally friendly hydrocarbon refrigerant

## OPTIONS:

- Lighted door graphic
- Graphics
- Left hinge units



Complies with 2017 DOE standards for commercial freezer and ice cream freezer

## TECHNICAL SUMMARY

MODEL	SIZE				ELECTRICAL		REFRIGERATION			OTHER	
	Dimensions (inches)* Width x Depth x Height	Cubic Feet	Net Weight (lbs.)	Shipping Weight (lbs.)**	Voltage/Hz/Phase	Running Amps	Compressor HP	Refrigerant	Temperature	No. of Optional Shelves	Container Quantity
CTF-1T	16 1/8 x 15 3/4 x 31 1/2	1.3	73	82	115/60/1	1.2	1/5	R-600a	-15°F to +15°F	2	375
CTF-2T	16 1/8 x 15 3/4 x 39 3/8	2.0	82	93	115/60/1	1.4	1/5	R-600a	-15°F to +15°F	3	250

\*Dimensions are all nominal lengths

\*\*Does not include weight of pallets when needed

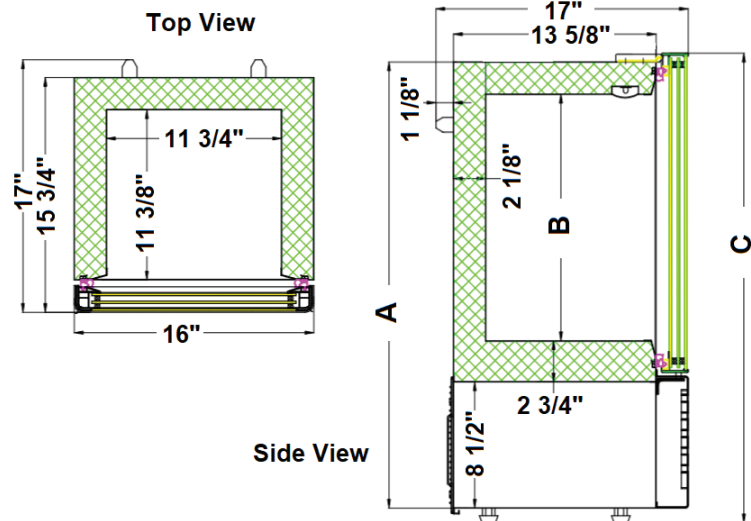

	A	B	C
CTF-1T	30"	16 1/2"	31 1/2"
CTF-2T	37 7/8"	24 3/8"	39 3/8"



500 S. Falkenburg Road  
Suite 200 | Tampa, FL 33619  
800.441.4014 | 813.870.0340  
www.excellenceindustries.com  
ver. 06.20