



**John  
BOOS**  
Since 1887

ITEM #: \_\_\_\_\_ QTY: \_\_\_\_\_

MODEL #: \_\_\_\_\_

PROJECT NAME: \_\_\_\_\_

070919

3601 S. Banker St. Effingham, IL 62401 • P.O. BOX 609 • Ph: (888) 431-2667 • Fax: (800) 433-2667

## **"GS6-GBK" EQUIPMENT STANDS**



### **GALVANIZED BASE**

#### **FEATURES:**

- 16GA TYPE 300 STAINLESS STEEL TOP WITH #4 POLISH, SATIN FINISH
- 1-1/2" STALLION EDGE ON FRONT. TURNED UP BACK AND BOTH SIDES
- TOP FRAME IS REINFORCED BY A FULL FRAME FABRICATED OF 1-1/2" SQUARE O.D. TUBE 16GA GALVANIZED STEEL
- GALVANIZED STEEL BASE
- SHIPPED KNOCKED-DOWN, EASY - TO - ASSEMBLE

#### **MATERIAL:**

- TOP: 16GA STAINLESS STEEL TYPE 300 STAINLESS STEEL WITH #4 POLISH, SATIN FINISH
- BRACING: 1-1/4" ROUND O.D. 18 GAUGE TUBULAR GALVANIZED STEEL
- LEGS: 1-5/8" ROUND O.D. 16 GAUGE TUBULAR GALVANIZED STEEL
- GUSSETS: GALVANIZED STEEL
- FEET: 1" ADJUSTABLE STAINLESS BULLET FEET

#### **CONSTRUCTION:**

- TOP: STAINLESS STEEL TOPS ARE TIG WELDED, EXPOSED WELDS ARE POLISHED TO MATCH ADJACENT SURFACE



#### **OPTIONAL ACCESSORIES**

DESCRIPTION	QTY
MAPLE CUTTING BOARDS	
WELDED SET-UP	

### **"GS6-GBK" EQUIPMENT STANDS W/ GALV BRACING BASE**

24" WIDE	QTY	30" WIDE	QTY	36" WIDE	QTY
GS6-2415GBK		GS6-3015GBK		GS6-3615GBK	
GS6-2418GBK		GS6-3018GBK		GS6-3618GBK	
GS6-2424GBK		GS6-3024GBK		GS6-3624GBK	
GS6-2430GBK		GS6-3030GBK		GS6-3630GBK	
GS6-2436GBK		GS6-3036GBK		GS6-3636GBK	
GS6-2448GBK		GS6-3048GBK		GS6-3648GBK	
GS6-2460GBK		GS6-3060GBK		GS6-3660GBK	
GS6-2472GBK		GS6-3072GBK		GS6-3672GBK	

# DETAILED SPECIFICATIONS

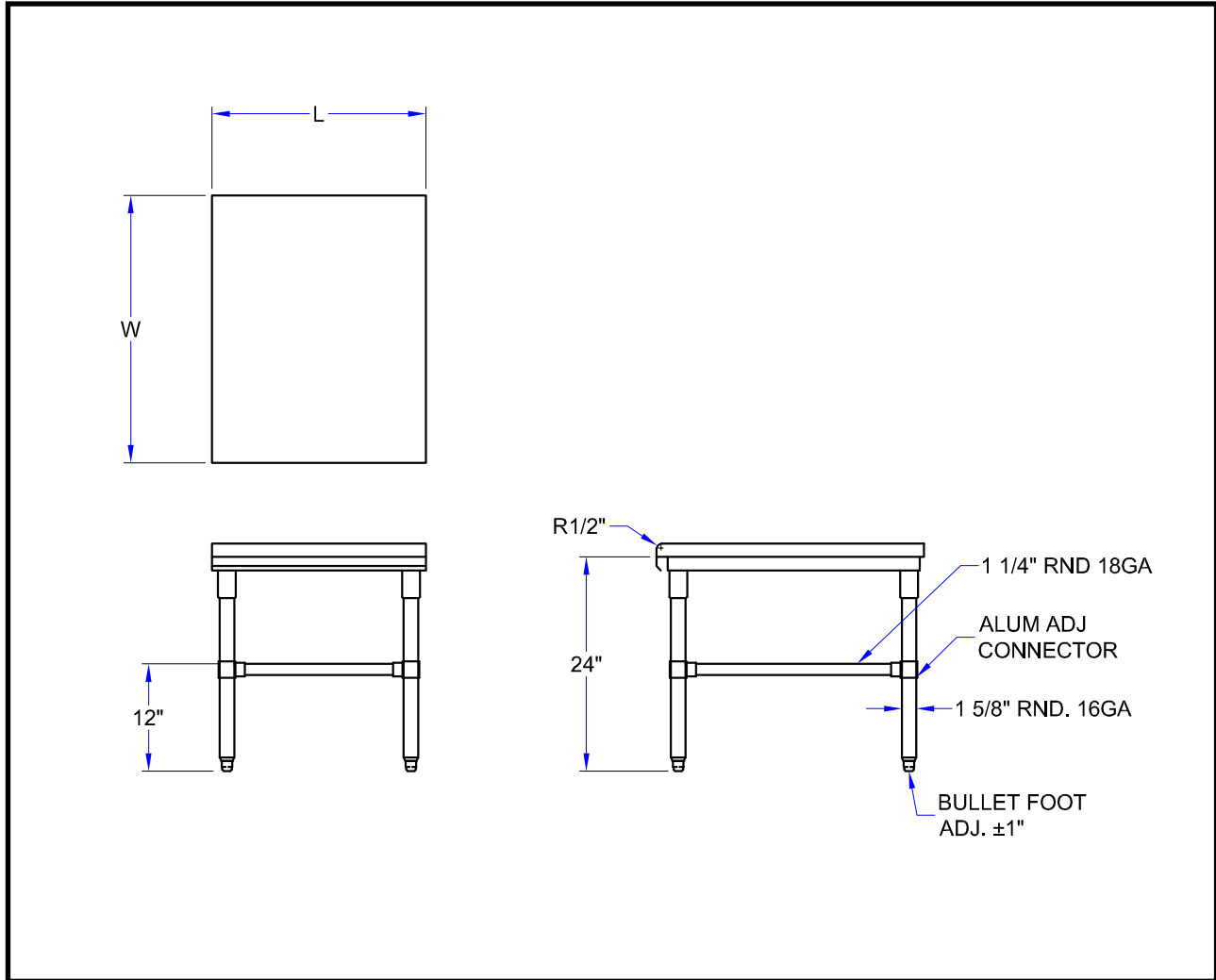

## "GS6-GBK" EQUIPMENT STANDS W/ GALV BRACING BASE

LENGTH	24" WIDE	WT. (LBS)	30" WIDE	WT. (LBS)	36" WIDE	WT. (LBS)
15"	GS6-2415GBK	30	GS6-3015GBK	36	GS6-3615GBK	38
18"	GS6-2418GBK	36	GS6-3018GBK	40	GS6-3618GBK	44
24"	GS6-2424GBK	47	GS6-3024GBK	51	GS6-3624GBK	55
30"	GS6-2430GBK	55	GS6-3030GBK	60	GS6-3630GBK	70
36"	GS6-2436GBK	65	GS6-3036GBK	69	GS6-3636GBK	73
48"	GS6-2448GBK	80	GS6-3048GBK	90	GS6-3648GBK	100
60"	GS6-2460GBK	95	GS6-3060GBK	111	GS6-3660GBK	127
72"	GS6-2472GBK *	111	GS6-3072GBK *	132	GS6-3672GBK *	154

\*NOTE: 3 SETS OF LEGS

SOME UNITS SHIP UNASSEMBLED FOR REDUCED SHIPPING COST. ALL DIMENSIONS ARE TYPICAL. TOLERANCE +/- .500"

John Boos & Co. is constantly engaged in a program of improving products and therefore reserves the right to change specifications without prior notice.



Boos  
locks

AQ AutoQuotes

3601 S. Banker St. • Effingham, IL 62401 • PO BOX 609 • quotes@johnboos.com

[www.johnboos.com](http://www.johnboos.com)

112020

79